

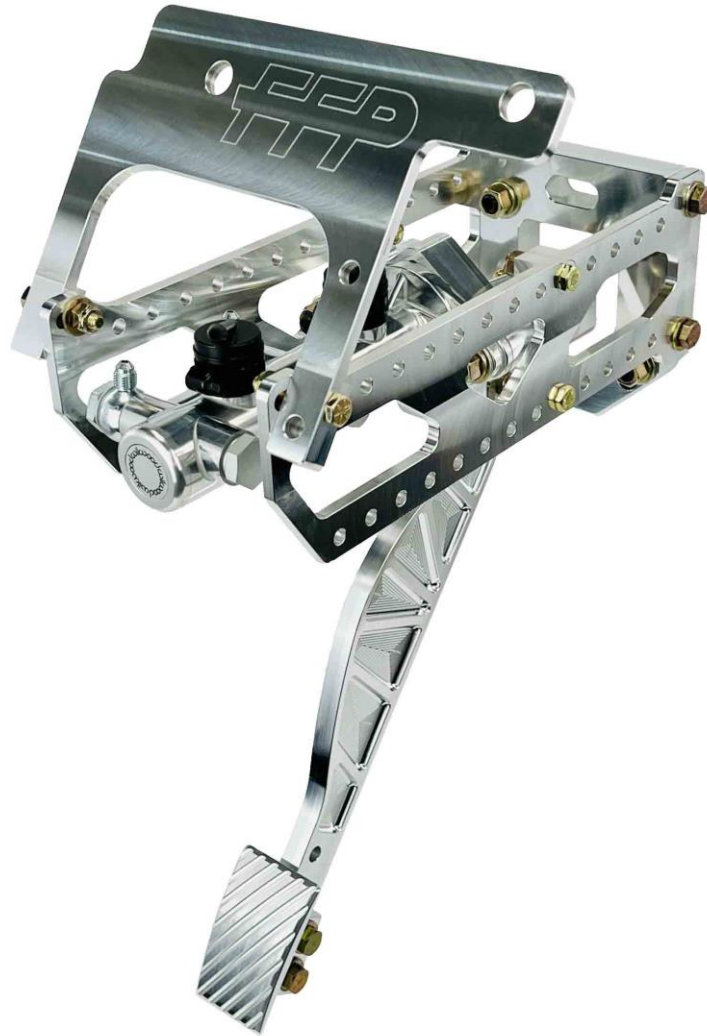

(813) 928-1449

[www.FFPCustoms.com](http://www.FFPCustoms.com)

# 1979-1993 Mustang Pedal Assembly Main Structure & Brake Pedal Instructions



FFP Customs prides itself on not only manufacturing quality parts, but also offering real world, race car solutions. Our Patented Pedal Assembly is another product aimed at improving your experience behind the wheel of your race car. These instructions are designed to make installing your new FFP Customs Pedal Assembly that much easier, so follow along as we guide you through the installation process.



When you open your FFP Customs pedal assembly box, this is how it will be arranged. Depending on the pedal assembly you have ordered, each individual pedal will be pre-assembled, as will the pedal assembly's main structure, off which everything is built. So, along with the subassemblies, and Wilwood master cylinder box, we also have hardware bags that go with the appropriate subassembly. With the main structure and brake pedal assembly we include hardware bags for the pedal pad, cowl panel mount, reservoir mount, and brake master cylinder mount.

## Pedal Assembly Contents

- Pedal Assembly main structure, preassembled.
- Brake Pedal pre-assembled.
- Throttle Pedal, if applicable.
- Clutch Pedal, if applicable, pre-assembled.
- Pedal Pads for each included pedal.
- Brake Fluid Reservoir Mount.
- Wilwood Master Cylinder.
- Hardware Bags for each component.



The Pedal Assembly's main structure installs using the outside firewall mount and the inside firewall mount. The main structure is the building block of the pedal assembly. Everything is built off the main structure. The main structure bolts to the firewall and the cowling area under the dash. The cowl mount is part of the main structure and that part bolts to the main structure and cowling area. Then the brake master cylinder and brake pedal are attached to the main structure in the center.

The main structure is the key to our pedal assembly. Once you have the main structure installed, the rest of the installation is a matter of adding the brake pedal and master cylinder, the throttle pedal, and

if applicable, the clutch pedal. When you receive it, the main structure's inside and outside firewall mount is already attached. Detach the outside firewall mount and feed its studs through the factory power booster holes in the firewall. Then, on the inside, attach the main structure to the studs, and bolt the two together. Next, take the supplied two 5/16-18 bolts with washers, and fasten the front cowl panel to the factory mounting holes on the cowl.

The master cylinder bolts to the brake pedal and the master cylinder mount, and then the subassembly is fitted to the center of the main structure. Once a comfortable seating position has been attained, mark the main structure where you want to mount the brake pedal and master cylinder. The brake pedal and master cylinder will need to be removed and bench bled prior to final assembly.

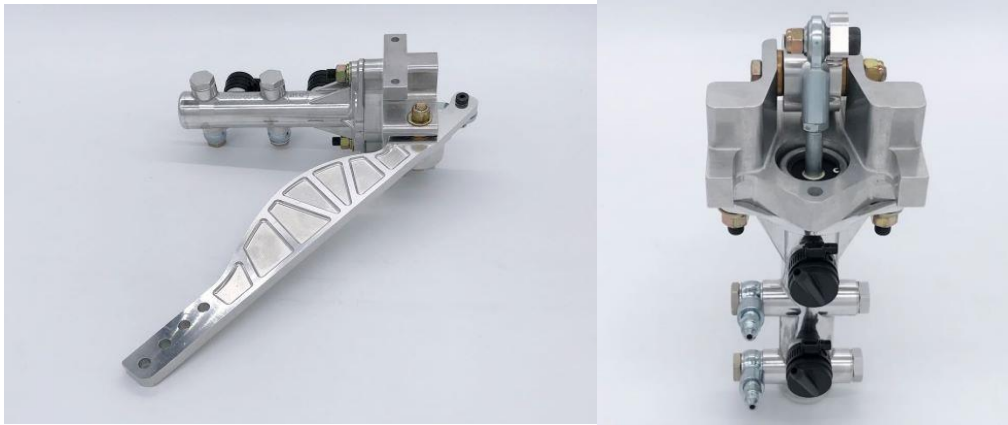

*Not only is the brake pedal assembly adjustable fore and aft, but you can also adjust pedal height, thanks to extra holes at the bottom of the brake pedal. Attach the included Wilwood master cylinder to the brake pedal subassembly and it is ready to be attached to the main structure. We include a threaded Heim joint to connect the master cylinder to the brake pedal at the top. The Heim joint shoulder bolt and nut needs to be arranged in this fashion to provide clearance for full brake pedal travel. This is looking down at it from overhead. Make sure not to preload the master cylinder or you could cause brake drag.*

*With the main structure, brake pedal and master cylinder installed, do not tighten everything until you have adjusted it to your liking and bled the master cylinder. With the master cylinder bled and everything firmly attached, the brake pedal portion of the install is done.*



*The main structure/brake pedal assembly includes this reservoir mount for the brake master cylinder. This mount is designed to use the roll bar running behind the dash, but if you don't have that, the reservoirs still need to be mounted above the master cylinder for proper operation as they are gravity fed.*

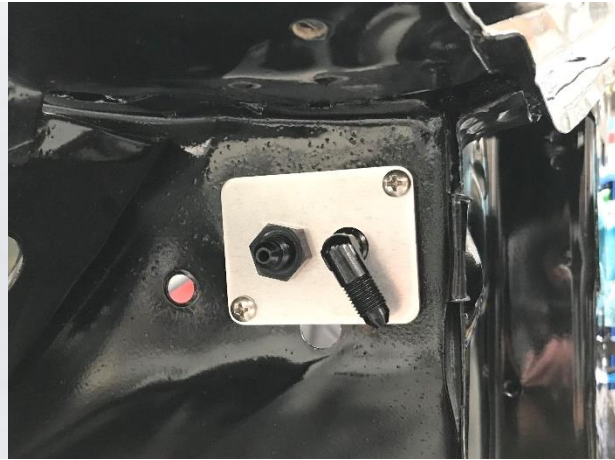

- ½" Banjo bolt
- 9/16" Inner diameter sealing washer
- -3AN Banjo
- ½" Inner diameter sealing washer

This is the correct orientation for the pressure output fittings that will be screwed into the brake master cylinder.

*These lines, fittings, and brake light switch are included with the pedal assembly. These fittings and lines connect the master cylinder to the bulkhead at the firewall (right). We attach the bulkhead to the firewall/wheel well where the factory cruise control hoses pass through. The way we have the fittings laid out here on the bulkhead, you can easily run a line for the rear brakes using the 90-degree fitting, and the other to the Line-Loc and/or front brakes. This layout is just an example of how and where to mount the bulkhead and fittings.*

If you have made it this far, you have completed the installation of the FFP Customs Patented Pedal Assembly's main structure and brake pedal subassembly. If you have also ordered a throttle pedal and/or clutch pedal subassembly as part of your FFP Customs pedal assembly, we have included separate instruction sheets to ease the installation of those subassemblies.

If you have any installation concerns or roadblocks, please call us. We would rather you call us for clarification instead of being frustrated with the installation.

Proudly Made in the USA.

FFP Customs

(813) 928-1449

[www.FFPCustoms.com](http://www.FFPCustoms.com)